



ITW BGK

**Electric Infrared
Curing Solutions**

AutoCure™ 5000//

Portable Heater

The AutoCure™ 5000// Portable Heater provides energy in the infrared spectrum through the use of specially designed emitters and reflectors. This unit is engineered specifically to dry spot repairs and is available in a variety of sizes. The Portable Heater incorporates ITW BGK patented control technology for process accuracy and consistency; and are completely wired, tested and built to industry standards.

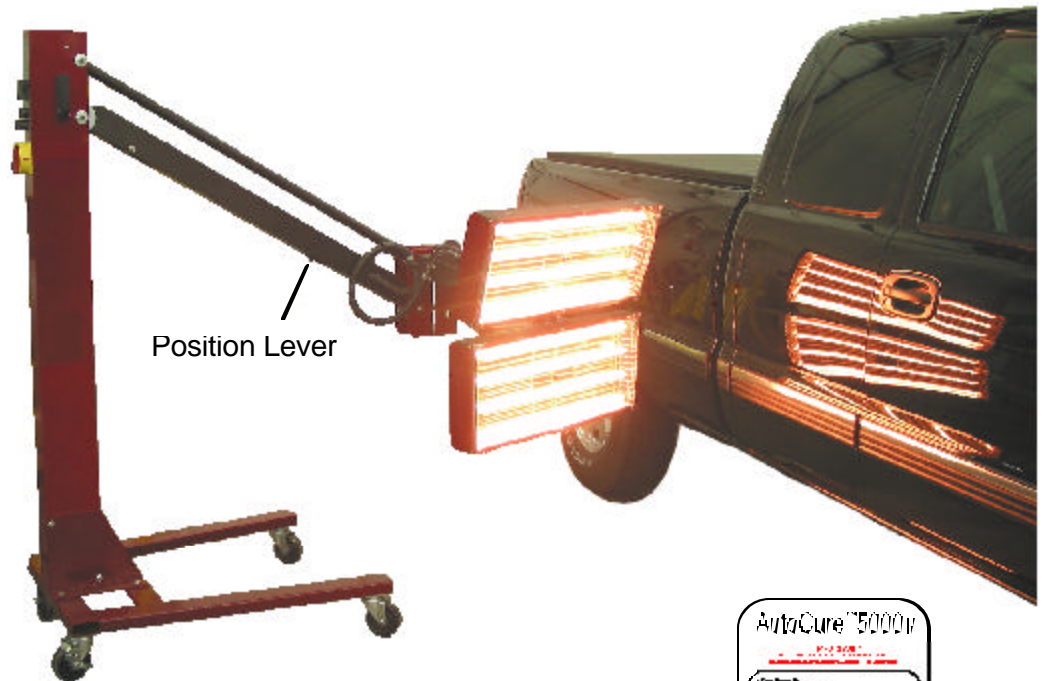

Patented Features:

Laser-Sighting
Patent 5,335,308

Closed Loop Temperature Control
Patent 5,050,232

Primary features are:

- Accurate to $\pm 5^{\circ}\text{F}$
- Automatic control
- Automatic timed heat cycle
- Cycle-time-remaining display
- Automatic shut-off
- Heater remains in place without locking handles
- Locking wheels to maintain position
- Single or dual temperature setpoint capability
- Heating range to 400°F (204°C)

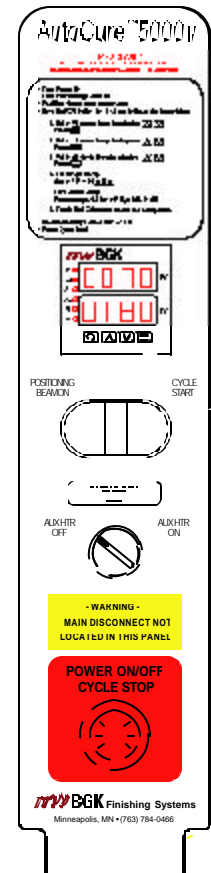

Control Panel



AutoCure™ 5000//

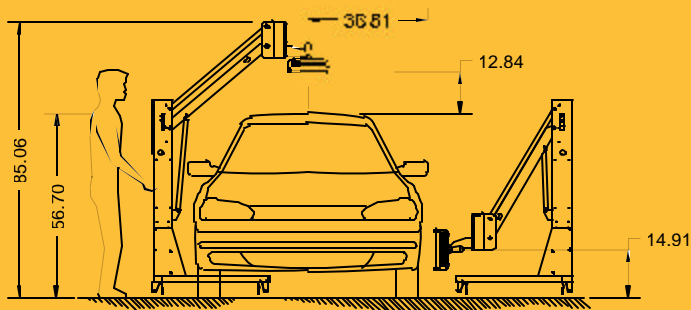
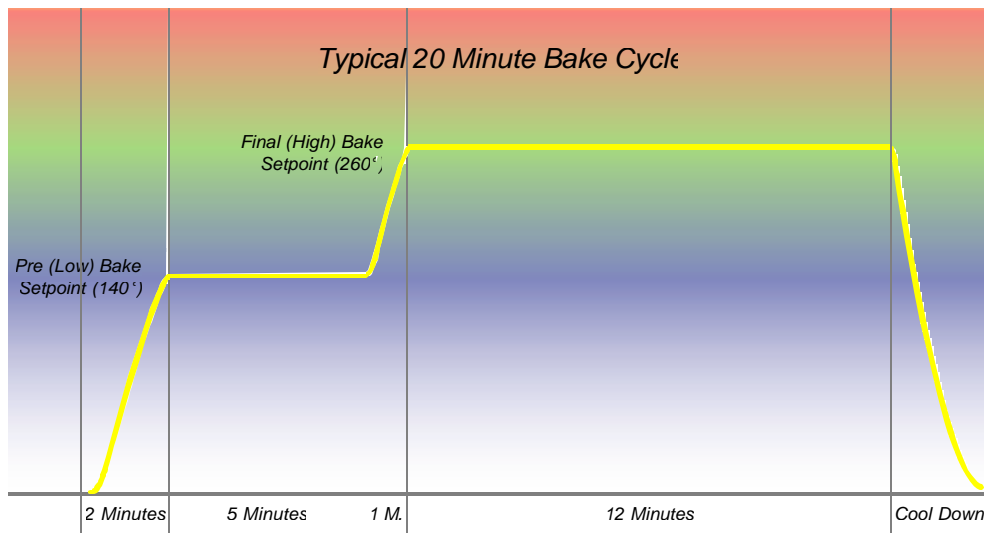

Car Model

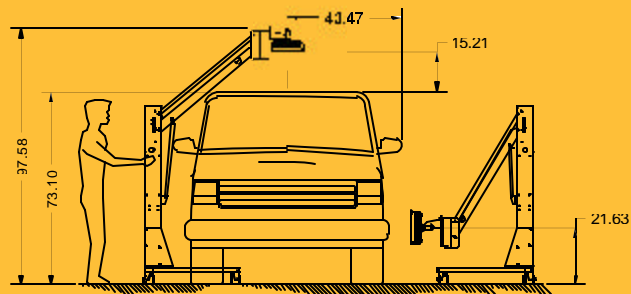

SUV/Truck Model

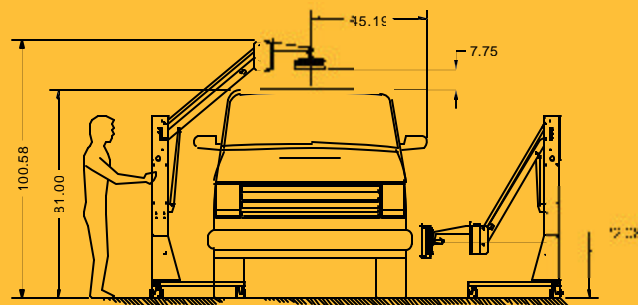

Commercial Truck Model

AutoCure™ 5000//
Examples

**Curing Paint...
It's What We Do.**

ITW BGK Finishing Systems
4131 Pheasant Ridge Drive NE
Minneapolis, MN 55449-7102
Office (763) 784-0466
Fax (763) 784-1362
itwbkg.com

